

# **Creda**

## **E530E / R530E**

### **Installation & User Instructions**

**You must read these instructions prior to using the appliance and retain them for future reference.**



For more information on our exciting product range ring  
**Creda Answer Centre 08701 54 64 74**

OR



Visit us on the **NET** at  
**<http://www.creda.co.uk>**

Our site invites you to make use of our **interactive cookbook** and **product selector**. Feel free to **browse our product range** to see what's **bubbling away** at the moment or to **ask for help** on our products and services

# Creda

General Domestic Appliances Ltd. Morley Way Peterborough PE2 9JB  
**Creda Answer Centre** 08701 54 64 74  
**Web** <http://www.creda.co.uk>

It may be necessary from time to time to change the specification outlined in this booklet without notice. Any change which is made will not affect your statutory rights.

---

# Contents

---

Introduction	4
Safety Information	5
Features	7
Controls	8
Oven Timer Operation	9
Grill Pan and Handle	15
Using the Top Oven for Solarplus Grilling	16
Operation when using Top Oven for Grilling	17
Solarplus Grill Chart	18
Using the Top Oven as a Convection Oven	19
Operation when using the Top Oven as a Convection Oven	20
Main Oven (Pre-Heat)	21
Using the Main Oven for Fan Cooking	22
Using the Main Oven for Convection Cooking	23
Using the Main Oven for Other Functions	24
Temperature Conversion Chart	25
Oven Temperature Charts	26
Cooking Results Not Satisfactory?	30
Care and Cleaning	31
Installation	35
Something Wrong?	39
Key Contacts	Back Cover

---

# Introduction

---

Your new appliance is guaranteed\* and will give lasting service. This guarantee is only applicable if the appliance has been installed in accordance with the installation instructions detailed in this booklet.

To help make best use of your cooking equipment, please read this booklet carefully.

The cooker is designed specifically for domestic use and responsibility will not be accepted for use in any other installation.

**When the cooker is first used an odour may be emitted,  
this will cease after a period of use**

When first using the cooker ensure that the room is well ventilated (e.g. open a window or use an extractor fan) and that persons who may be sensitive to the odour avoid any fumes. It is suggested that any pets be removed from the room until the smell has ceased. This odour is due to temporary finish on oven liners and elements and also any moisture absorbed by the insulation.

**\* The guarantee is subject to the provisions that the appliance:**

- (a) Has been used solely in accordance with the Users Instruction Book.**
- (b) Has been properly connected to a suitable supply voltage as stated on the rating plate attached to this equipment.**
- (c) Has not been subjected to misuse or accident or been modified or repaired by any person other than the authorised employee or agent.**
- (d) Has been correctly installed.**

## Disposal of your product

To minimise the risk of injury to children please dispose of your product carefully and safely. Remove all doors and lids. Remove the mains cable (where fitted) by cutting off flush with the appliance and always ensure that no plug is left in a condition where it could be connected to the electricity supply.

To help the environment, Local Authority instructions should be followed for the disposal of you product.

This appliance conforms to the following EEC Directives:

Electromagnetic Compatibility  
89/336/EEC  
92/31/EEC  
93/68/EEC

Low Voltage Equipment  
73/23/EEC  
93/68/EEC



---

# Safety Information

---

**When used properly your appliance is completely safe but as with any electrical product there are certain precautions that must be observed.  
PLEASE READ THE PRECAUTIONS BELOW BEFORE USING YOUR APPLIANCE.**

## Always

- Always make sure you remove all packaging and literature from inside the oven and grill compartments before switching on for the first time.
- Always make sure you understand the controls prior to using the appliance.
- Always keep children away from the appliance when in use as the surfaces will get extremely hot during and after cooking.
- Always make sure all controls are turned off when you have finished cooking and when not in use.
- Always stand back when opening an oven door to allow any build up of steam or heat to disperse.
- Always use dry, good quality oven gloves when removing items from the oven/grill.
- Always take care to avoid heat/steam burns when operating the controls.
- Always turn off the electricity supply at the wall switch before cleaning and allow the appliance to cool.
- Always make sure the shelves are in the correct position before switching on the oven.
- Always keep the oven and grill doors closed when the appliance is not in use.
- Always take care when removing utensils from the top oven when the main oven is in use as the contents may be hot.
- Always keep the appliance clean as a build up of grease or fat from cooking can cause a fire.
- Always follow the basic principles of food handling and hygiene to prevent the possibility of bacterial growth.
- Always keep ventilation slots clear of obstructions.
- Always refer servicing to a qualified appliance service engineer.
- During use the oven becomes hot. Care should be taken to avoid touching heating elements inside the oven,

## SAFETY ADVICE

### IN THE EVENT OF A CHIP PAN OR ANY OTHER PAN FIRE:

1. TURN OFF THE COOKER APPLIANCE AT THE WALL SWITCH.
2. COVER THE PAN WITH A FIRE BLANKET OR DAMP CLOTH, this will smother the flames and extinguish the fire.
3. LEAVE THE PAN TO COOL FOR AT LEAST 60 MINUTES BEFORE MOVING IT. Injuries are often caused by picking up a hot pan and rushing outside with it. NEVER USE A FIRE EXTINGUISHER TO PUT OUT A PAN FIRE as the force of the extinguisher is likely to tip the pan over. Never use water to extinguish oil or fat fires.

---

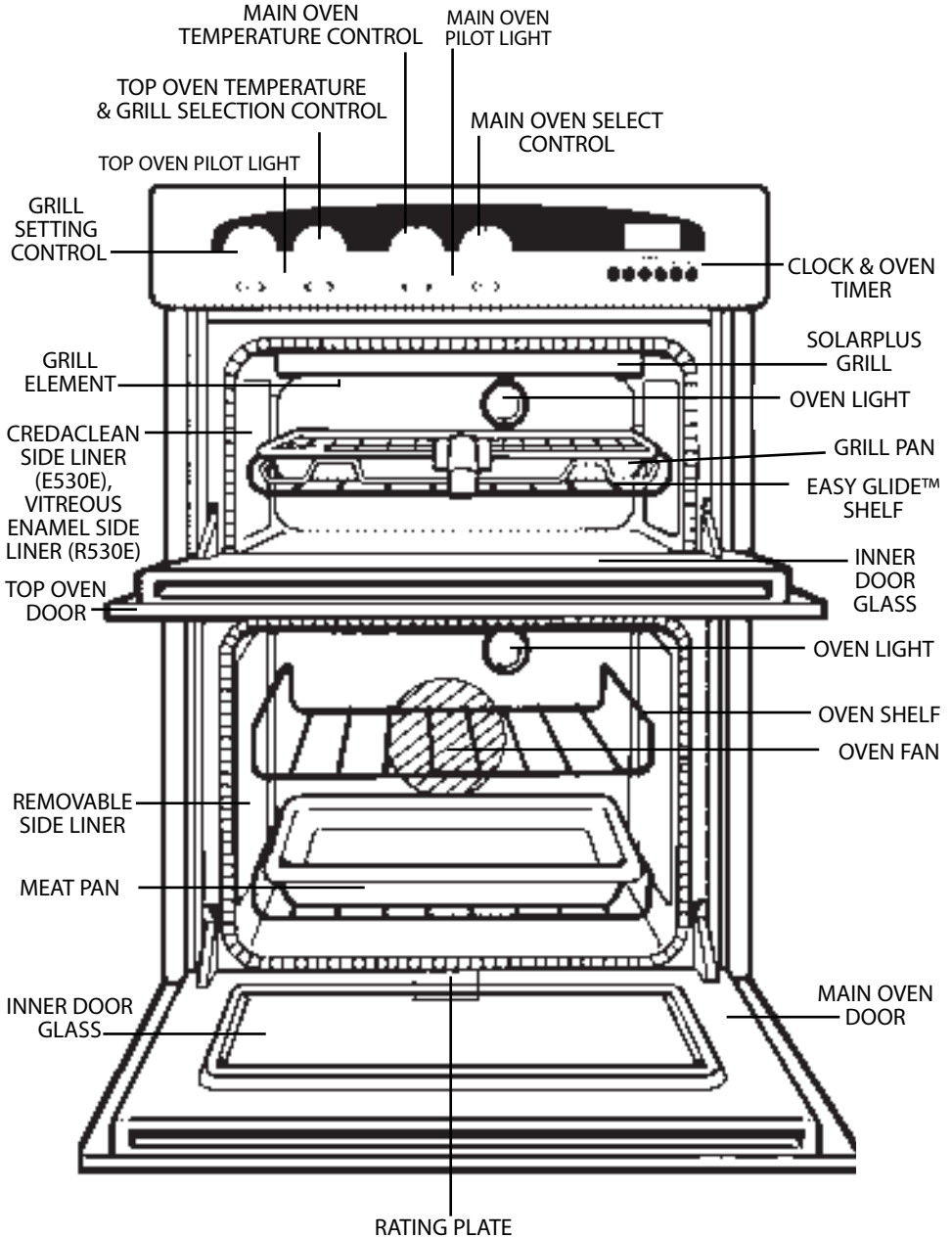
# Safety Information

---

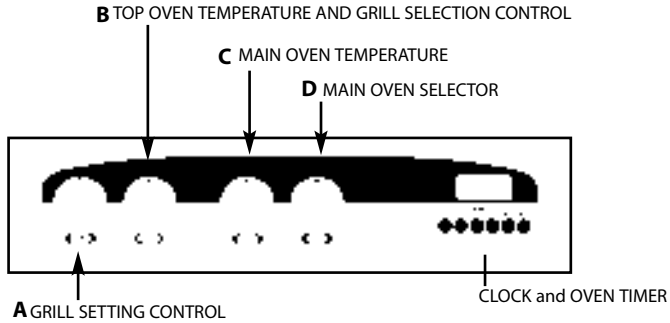
## Never

- Never leave children unsupervised where a cooking appliance is installed as all cooking surfaces will be hot during and after use.
- Never allow anyone to sit or stand on any part of the appliance.
- Never store items above the appliance that children may attempt to reach.
- Never remove the oven shelves whilst the oven is hot.
- Never heat up unopened food containers as pressure can build up causing the container to burst.
- Never store chemicals, food stuffs or pressurised containers in or on the appliance, or in cabinets immediately above or next to the appliance.
- Never operate the grill with the door closed as this will cause the appliance to overheat.
- Never use the appliance as a room heater.
- Never use the grill to warm plates.
- Never dry any items on the oven doors.
- Never install the appliance next to curtains or other soft furnishings.
- Never allow children to play with the appliance controls.
- Never use 'steam cleaners'.

# Features



# Controls



## Control Markings

## Function

Control Knob	Description	Function
<b>A</b>	<b>Grill Setting Control</b>	Selects the heat at which the grill will cook the food. <b>1 - 6 Grill Settings Control:</b> <b>1 = Low, 6 = High</b>  <b>Note:</b> To grill you must first select a grill function using control (B).
<b>B</b>	<b>Top Oven Temperature &amp; Grill Selection Control</b>	<div style="border: 1px solid black; padding: 2px; display: inline-block;">100 - 220</div> Selects the cooking temperature (Degrees Centigrade) when using the top oven as a conventional oven.  <div style="border: 1px solid black; padding: 2px; display: inline-block;">Half Grill</div> Switches the top oven to "Half Grill" mode.  <div style="border: 1px solid black; padding: 2px; display: inline-block;">Full Grill</div> Switches the top oven to "Full Grill" mode.
<b>C</b>	<b>Main Oven Temperature</b>	<div style="border: 1px solid black; padding: 2px; display: inline-block;">80 - 230</div> <b>Main Oven Temperature Scale (In Degrees Centigrade).</b> - When cooking select the required cooking temperature.
<b>D</b>	<b>Main Oven Selector</b>	<div style="border: 1px solid black; padding: 2px; display: inline-block;">Fan Oven</div> This position is for Fan Oven cooking  <div style="border: 1px solid black; padding: 2px; display: inline-block;">Side Heat</div> This position is for Convection cooking.

### Cooling Fan:

A gentle flow of air will be blown below the control panel when any selector switch is used.

**Note:** Whenever the appliance has been used, the cooling fan may run on or restart itself after all the controls have been turned off. This indicates that the appliance is still warm.

### Oven Interior Lights

The oven lights are operated when their respective oven control is used. (N.B. Not all models have a top oven interior light).

### Slow Cooking

The main oven has a "90° setting" this can be used for slow cooking, keeping food warm and warming plates for a short period. Full details of this can be found in the Slow Cooking section.

**Note: After use, it is advisable to check that all oven controls have been switched off.**



---

# Oven Timer Operation

---

**NOTE: The Timer must be set to 'Time of Day' and 'Manual' before the ovens can be used.**

## Automatic Cooking

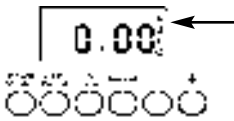
The Main Oven can be controlled by the automatic timer.

**NEVER operate the grill or top oven when the main oven is set to cook automatically, because the oven cavity can become warm and this may cause bacterial growth in food.**

## Hints on Automatic Cooking

1. Select foods which require the same cooking time and temperature.
2. To ensure food does not cool down and does not require reheating set the end time so that the food is ready when you require it.
3. Always ensure that meat and poultry is defrosted before placing in the oven.
4. Whenever possible, take food out of the refrigerator and keep it as cool as possible.
5. If cooking food that requires frying before placing in the oven for auto cooking, keep the delay start time to a minimum,.
6. Never place hot or warm food in the oven for delay start cooking as it could cause the oven to be warm and produce harmful bacteria in food.
7. We advise that dishes containing left-over, cooked poultry or meat eg. Shepherd's Pie, should not be cooked automatically if there is to be a time delay period.
8. Ensure that delay start times are kept to a minimum to prevent bacterial growth in food.
9. Wine or beer may ferment and cream may curdle during the delay period so it is best to add these ingredients just before serving.
10. Foods which discolour should be protected by coating in fat or tossing in water to which lemon juice has been added, prior to placing food in the oven.
11. Dishes containing liquid should not be filled too full to prevent boiling over.
12. Food should be well sealed (but not airtight) in a container to prevent the loss of liquid during cooking. Aluminium foil gives a good seal.
13. Always ensure that food is piping hot and cooked thoroughly before serving.
14. Only reheat food once.

# Know Your Timer



## CLOCKFACE



The timer incorporates a 24 hour clock.


**Ensure the correct time of day is always set, before using your cooker.**

**PLEASE NOTE THAT THE DISPLAY WILL DIM BETWEEN 22.00 HOURS AND 06.00 HOURS TO PREVENT GLARE.**

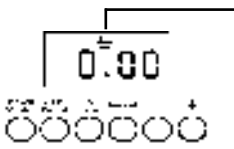
**However, should you operate the timer during these hours the display will return to normal brightness for a few seconds and then dim again.**

## SYMBOLS

 will light up when you select a Minute Minder Period and will remain lit for the period set. At the end of the Minute Minder Period, the timer will emit an audible tone for 2 minutes, the  symbol will start to flash and will continue to flash until the Minute Minder function is cancelled.

 This "Cookpot" symbol will light up either:-

- When you press the Cook Period Button and set a length of time for an Auto Cooking Programme. (It will go out again a few seconds after you release the timer buttons).
- During the actual Cook Period.



"AUTO" will light up:-

- When the timer is first turned on it will flash. (It will go out when a time of day is set).
- When an Auto Cooking Programme has been set.

The "Auto" symbol will flash at the end of an Auto Cooking programme to indicate that the programme has finished.

***(When the "Auto" symbol is flashing, to return the oven to Manual operation, turn the oven controls off, ensure that the correct time of day is set, and press the "Manual" button twice – The "Auto" symbol will go out.)***

**Note:** If at any time the display shows a 'KEY' symbol, it is likely that the timer has been set incorrectly. OVEN COOKING IS NOT POSSIBLE. The 'KEY' symbol can be deleted and the cooker returned to manual operation by:

- Simultaneously pressing the Minute Minder and the Cook Period buttons for a period of approximately 8 seconds.
- Releasing the buttons and pressing the '+' button.

## TIMER FUNCTION BUTTONS

### Minute Minder Button

Here you can set a time period of up to 23 hours 59 minutes, that will count down. When it reaches zero, the timer will emit an audible tone.

**For Example:** If you set 20 minutes, the audible tone will occur 20 minutes later.

## AUTO COOKING PROGRAMME

### Cook Period Button

Cook Period is the actual length of time for which, the timer will switch the oven(s) on as part of an "Auto Cooking" programme.

(e.g. If you set 2 hours, the food will be cooked for 2 hours).

### End Time Button

The time of day at which you want an "Auto Cooking" programme to **end**.

**For Example:** If you set a "Cook Period" for 2 hours, and "End Time" of 11:00. The timer will switch the oven(s) on at 9:00 and turn the oven(s) off at 11:00. You will hear a audible tone at 11:00, to indicate that the Auto Cooking Programme has finished.

### Notes:

- When setting an Auto Cooking programme you will need to set the oven controls(s) to the required temperature(s) when you set the timer.
- If an Auto Cooking programme has been set the oven(s) will only operate during the pre-programmed time.

### Manual Button

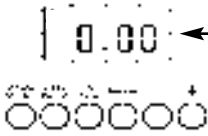
Needs to be pressed to cancel an Auto Cooking programme and return the oven(s) to Manual operation.

### "+" and "-" Buttons

Used to adjust the various timer function settings.

# Electronic Clock and Automatic Oven Timer Operation

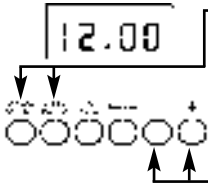
## SETTING THE TIME OF DAY



**Step 1** Make sure all oven controls are turned Off.

**Step 2** Check the electricity supply to the cooker is turned on.

**Step 3** When switched on the display will show 0.00 and Auto symbol will be flashing intermittently.



**Step 4** Press & hold in both the "Minute Minder" & "Cook Period" button together.

**Step 5** With the "Minute Minder" & "Cook Period" buttons still held in, press either the "+" or "-" buttons to set the correct time of day.

**Step 6** Release all the buttons simultaneously.

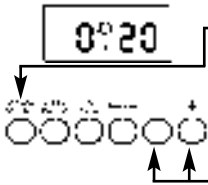
**THE TIME OF DAY IS NOW SET.**

*To change the time of day repeat Steps 4, 5 & 6 above.*

**Note:** You cannot adjust the time of day if the timer has been set for an Auto Cooking Programme.

## SETTING THE MINUTE MINDER



**Step 1** Ensure the time of day is set correctly.

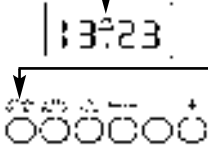


**Step 2** Press and hold the Minute Minder Button, a  symbol will light up.

**Step 3** With the "Minute Minder" button held in, set the required Minute Minder time using the "+" and "-" buttons.

Release all buttons and the timer display will revert back to the time of day. Bell symbol will remain lit to signify that a Minute Minder period has been set.

At the end of the set time a bleeping sound will be heard, and the  symbol will flash for approximately 2 minutes. After approximately 2 minutes the bleeping sound will stop and the  symbol will go out automatically.



**Step 4** To cancel the bleeping sound within the two minutes press the Minute Minder button.

**Note 1** When the Minute Minder has been set, the time remaining can be checked at any time by simply pressing the Minute Minder button.

**Note 2** If necessary the Minute Minder can be cancelled before the tone sounds by pressing and holding the Minute Minder button and then at the same time pressing the "-" button until 0.00 appears in the display window.

# Electronic Clock and Automatic Oven Timer Operation

## AUTO COOKING PROGRAMMES

There are two Auto Cooking programmes that can be selected using your timer:-

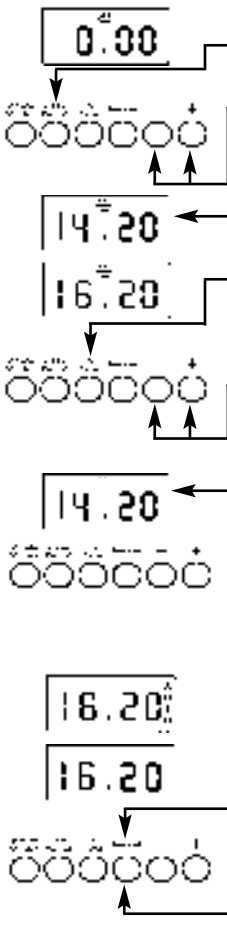
- (a) To set the timer to switch the oven(s) On and Off Automatically
- (b) To set timer to switch on immediately and OFF automatically after a set cook period.

### a) TO SET THE TIMER TO SWITCH THE OVEN(S) ON AND OFF AUTOMATICALLY

*This allows you to cook at a specified time for a chosen period before the oven switches off Automatically.*

**Step 1** Check that the correct time of day is set, if not follow instructions for setting the time of day.

**Step 2** Place food onto the correct shelf position in the oven and close the oven door(s).



**Step 3** Press and hold in the Cook Period button. The display will read 0.00 with the cookpot (☺) symbol lit.

**Step 4** With the Cook Period button still held in, set the required Cook Period using the "+" and "-" buttons.

Release the buttons and the timer display will revert to the time of day with the Auto symbol and Cookpot (☺) symbol lit.

**Step 5** Press and hold in the "End Time" button. The display will read the earliest possible end time for the Cook Period that you have set above. The Auto symbol and Cookpot (☺) symbol lit.

**Step 6** With the End Time button still held in, use the "+" and "-" buttons to set the "End Time" (i.e. The time you require the oven to switch off). Release all the buttons and the timer will revert back to the time of day.

The "Auto" symbol will remain lit to signify that an Auto Cooking Programme has been set. The (☺) symbol will go out.

**Step 7** Turn the oven control(s) to the required temperature, and if necessary select the appropriate oven function.

**Note: If your appliance has two ovens: When the timer has been set for one oven it is possible to use the other oven only during the same Automatic programme.**

At the end of the Automatic Cook Period the Auto Symbol will flash and an intermittent bleeping sound will be heard. The bleeping sound will continue for approximately 2 minutes unless cancelled. The "Auto" symbol will continue to flash until the timer is returned to Manual operation (see below).

**Step 8** Press the Manual button to cancel the bleeping sound. (If 2 minutes has not elapsed).

**Step 9** Turn the oven control(s) to the OFF position.

**Step 10** Press the manual button again to return the oven(s) to Manual Operation. (The Auto symbol will go out)

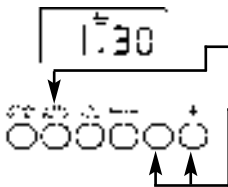
# Electronic Clock and Automatic Oven Timer Operation

**Note 1** When cooking automatically the Cook Period can be checked at any time by simply pressing the Cook Period button.

**Note 2** When cooking automatically the End Time can be checked at any time by simply pressing the End Time button.

## b) TO SET TIMER TO SWITCH ON IMMEDIATELY AND OFF AUTOMATICALLY AFTER A SET COOK PERIOD

- Step 1** Check that the correct time of day is set, if not follow instructions for setting the time of day.  
**Step 2** Place food onto the correct shelf position in the oven and close the oven door(s).  
**Step 3** Turn the oven control(s) to the required temperature, and if necessary select the appropriate oven function.

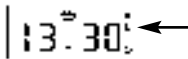


**Step 4** Press & hold in the "Cook Period" button, the display will read 0.00 and the cookpot (☺) symbol will light up.

With the Cook Period button still held set the required Cook Period using the "+" and "-" buttons. Example: 1hr 30 minutes (as shown).

**Note: Cook Period is the length of time the food requires to cook.**

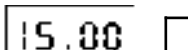
**Step 5** Release all buttons.



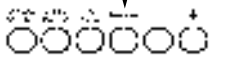
The timer display will revert to the time of day with the Auto symbol lit & Cookpot symbol remaining lit.

NOTE: The Cookpot symbol disappears

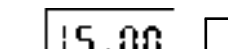
At the end of the Cook Period the "Auto" symbol will flash and an intermittent beeping sound will be heard. The beeping sound will continue for approximately 2 minutes unless cancelled. The "Auto" symbol will continue to flash until the timer is returned to Manual operation (see below).



**Step 6** Press the manual button to cancel the beeping. (If 2 minutes has not elapsed)



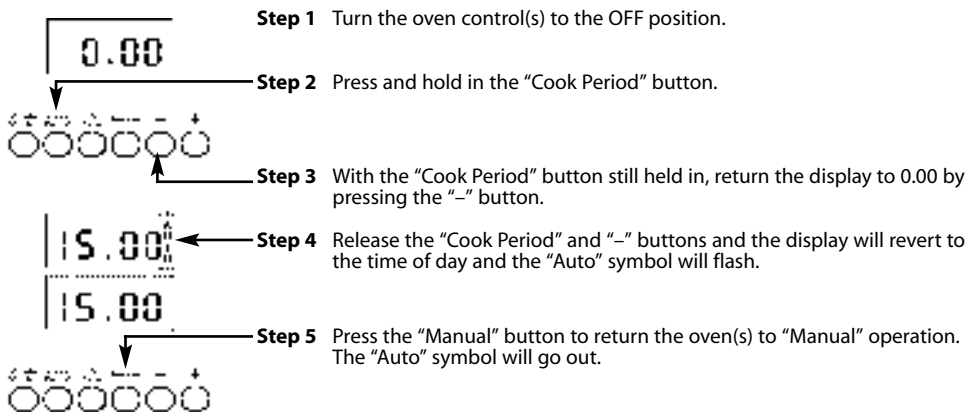
**Step 7** Turn the oven control(s) to the OFF position.



**Step 8** Press the "Manual" button again to return the cooker to Manual operation. (The Auto symbol will go out).

# Electronic Clock and Automatic Oven Timer Operation

## TO CANCEL AN AUTO COOKING PROGRAMME BEFORE THE COOK PERIOD HAS FINISHED.



**Note 1** When cooking automatically the Cook Period can be checked at any time by simply pressing the Cook Period button.

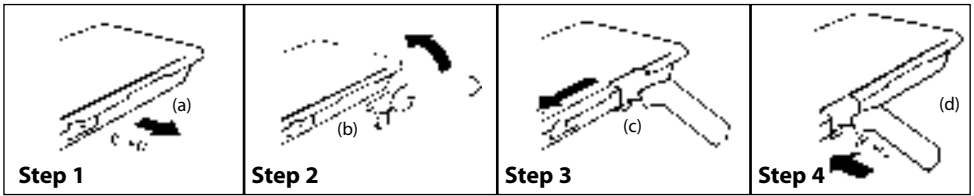
## OTHER NOTES ON TIMER OPERATION

1. When cooking Automatically the Cook Period can be checked at any time simply by pressing the Cook Period button.
2. When cooking Automatically the End Time can be checked at any time by simply pressing the End Time button.
3. Having set a Cook Period and End Time an electronic device stores the information. The device within the timer will switch the oven(s) on and off at the required times.
4. When setting an Auto Cooking Programme and a mistake is made, to clear:-
  - (a) Press and hold in the "Cook Period" button.
  - (b) With the Cook Period button still held in, return the display to 0.00 by pressing the "-" button.
  - (c) Release the "Cook Period" & "-" buttons, and the display will revert to the time of day and the "Auto" symbol will flash.
  - (d) Press & release the "Manual" button.
  - (e) Start the sequence again.
5. If at any time the display shows three flashing zero's 0.00. It is likely that the electricity supply to the oven has been interrupted. Reset the timer to the correct time of day.  
**Food in the oven may, therefore, not have been cooked, before serving check food is thoroughly heated and completely cooked.**
6. To set each function always press and hold the required function button and at the same time press "+" or "-" buttons.

**Note:** Between the hours of 22.00 & 06.00 the display dims to prevent glare. However, if you should operate a button during this period, the timer will return to normal brightness for a few seconds and then dim again.

# Grill Pan and Handle

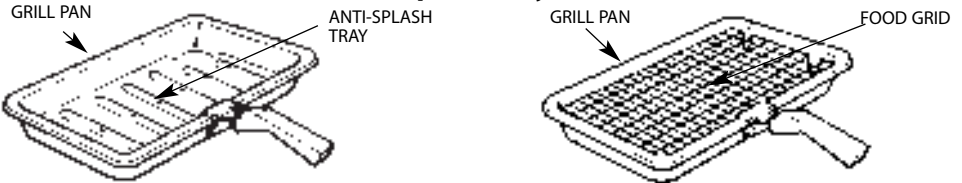
The grill pan handle is detachable from the pan, to facilitate cleaning and storage.  
The grill pan handle can be fixed as follows:



- Step 1** Remove the screw and washers from the grill pan bracket (a).
- Step 2** Tilt the handle over the recess (b).
- Step 3** Slide it towards the centre of the pan (c).
- Step 4** Locate the handle over the bracket (d).  
For a fixed handle, replace the screw and washers and ensure they are fully tightened up. If a detachable handle is required, do not replace the screw and washers.

**Note: If a fixed handle is required, the grill pan is unable to be kept in the main oven with the door closed but may be stored on the floor of the top oven with the door closed when the appliance is not in use.**

## Grill Pan Food Grid and Anti-Splash Tray

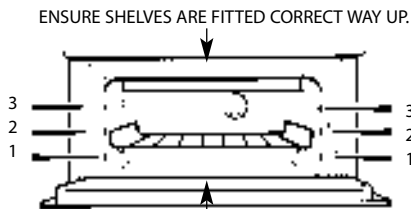


**Note: To stop fat splashing onto the grill mesh, it is important to use the anti-splash tray as shown in the grilling chart. Always clean the grill pan, anti-splash tray and food grid after each use.**

## Easy Glide™ Shelf

1. Only use Grill Pan supplied.
2. Never attempt to remove the Easy Glide™ Shelf with the grill pan in position.
3. Always withdraw the Easy Glide™ Shelf to its stop position before removing the grill pan (to avoid damaging the grill).

## Top Oven Shelf Positioning for Grilling



DO NOT PLACE FOOD/UTENSILS DIRECTLY ON THE OVEN FLOOR

# Using the Top Oven for Solarplus Grilling

Your cooker is not fitted with a conventional grill. **Creda** have developed a Solarplus high speed grill which is designed to reduce your grilling times. It is quicker because it takes less time to warm up from cold. Conventional grills require 5 minutes pre-heat before food is placed beneath them, but for normal grilling the Solarplus grill can be used directly from cold without any pre-heat.

However, when toasting, optimum performance is achieved by pre-heating the grill for about 1 minute.

**Note: You will notice that the grill elements are protected by a wire mesh. This stops you from touching live parts.**

**DO NOT under any circumstances insert objects into the grill mesh as this could damage the element wire, break the glass tubes or if the grill is on, cause electric shock.**

During use the mesh may become soiled. Care must be taken to ensure the grill mesh is not distorted – do not store the grill pan handle on the food grid when the shelf is in the highest position.

## Grilling Procedure



Fig 1

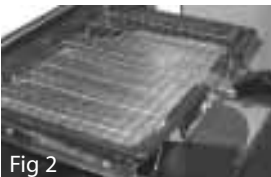


Fig 2

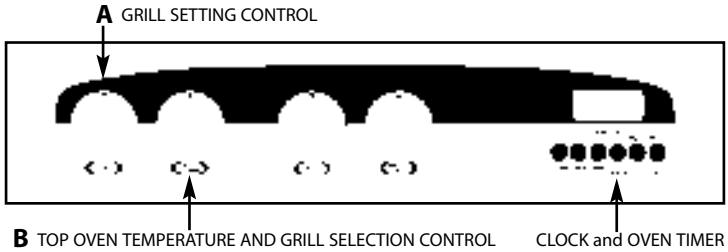
1. Open the grill/top oven door fully.
2. Ensure that the Easy Glide™ Shelf is located in the correct position.
3. Preheat the grill, if necessary, with the Easy Glide™ Shelf pulled out (Fig 1).
4. Locate the grill pan in the Easy Glide™ Shelf (see Fig 2) and push back under the element.
5. The grill pan should be withdrawn, always using the grill pan handle, to the stop position to turn or remove cooked food. (There is no need to remove the grill pan from the Easy Glide™ Shelf).
6. NEVER line the grill pan with aluminium foil as this may cause overheating of fat in the grill pan.

**NOTE:** To stop fat splashing onto the grill element mesh, it is important to use the anti-splash tray. Always clean the grill pan anti-splash tray and food grid after each use.

**NOTE:** Preheat the grill if, necessary, with the Easy Glide™ Shelf pulled out (Fig.1) Ensure that the Easy Glide™ Shelf is in the correct position. Leave the control at 6 for toast, and for fast cooking of foods. For thicker foods requiring longer cooking, turn the switch to a lower setting after the initial sealing on both sides at 6. The thicker the food, the lower the control should be set. **DO NOT** line the grill pan with aluminium foil, as this increases the amount of fat spitting which can cause a fire. After use always return both controls to their OFF (0) position.



# Operation when using the Top Oven for Grilling



**Step 1** Ensure that the Timer is set to manual.

**Step 2** Turn knob (B) clockwise to select grill function setting:

Set to:  For Half Grill (Left hand side only).

 For Full Grill.

**NOTE:** As you turn past the end of the oven temperature scale you will feel resistance on the knob – continue turning clockwise until the grill setting position is selected.

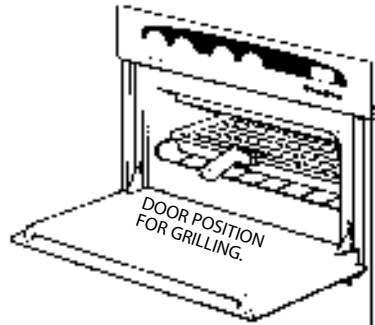
**Step 3** Turn knob (A) anti-clockwise to select the Grill Setting (1–6). (1=Low, 6=High).  
**Grill Controls Example:**

 = Full Grill Function

 = Maximum Grill Setting

**NOTE:** Do not grill with the grill/top oven door closed.

**Step 4** After use, turn both controls A & B to their off (●) position.



**DO NOT** allow young children near to the appliance when the grill is in use as the surfaces get extremely hot.

## Guide to Solarplus Grilling

<b>Food</b>	<b>Preheat oven for one minute</b>	<b>Easy Glide™ Shelf Position from base of oven.</b>	<b>Setting</b>	<b>Approximate Cooking Time</b>	<b>Pan to be used</b>
Toasting of Bread Products	Setting 6	3 or 2	Setting 6	3-5 minutes	Grill pan and food support
Small cuts of meat, Sausage, Bacon	None	3 or 2	Setting 6 for 4 minutes then reduce to Setting 5	10-15 minutes	Grill pan, anti-splash tray and grid
Chops etc. Gammon steaks	None	2	Setting 6 for 6-8 minutes then reduce to Setting 4 or 5	25-30 minutes	Grill pan, anti-splash trivet & food support
Fish Whole Fillets Fingers	None None None	2 3 3	Setting 6	6-8 minutes 10-15 minutes 10-15 minutes	Grill pan and food support
Pre-cooked Potato products	None	3 or 2	Setting 4	10-12 minutes	Grill pan and food support
Pizzas	None	3 or 2	Setting 4	10-12 minutes	Grill pan and grid
Browning of food eg. Cauliflower Cheese	Setting 6	3 or 2	Setting 6	5-10 minutes	Dish placed directly on the shelf

# Using the Top Oven as a Convection Oven

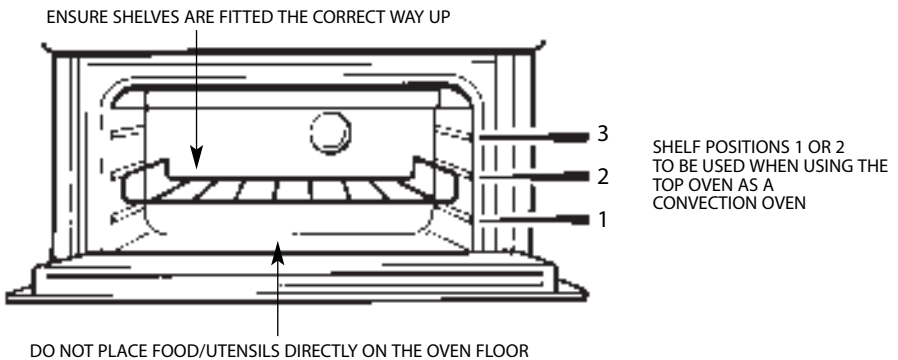
The top oven should be used to cook small quantities of food. The oven is designed so that the grill element operates at a reduced heat output, this is combined with a heating element situated underneath the floor of the oven. To ensure even cooking of the food it is important that cooking utensils are positioned correctly on the oven shelf so that the element is directly above. As a guide, the front of the utensil should be approx. 100mm (4") from the front of the shelf.

**Easy Glide™ Shelf** The Easy Glide™ Shelf, in conjunction with the grill pan supplied can be used for cooking in the oven(s), ie. meat, poultry etc. also for roasting vegetables. Place the Easy Glide™ Shelf in the oven on the same runner position as stated in the meat cooking charts.

**Important:** **Always** remove the grill pan handle from the grill pan when the pan is being used for oven cooking.  
**Always** use oven gloves when basting, turning or removing food from the oven, as the Easy Glide™ Shelf and the grill pan will be **hot**.  
**Never** remove the Easy Glide™ Shelf from the oven with the grill pan and food still in position.

**Note: Charts are a guide only, to suit personal taste and requirements, it may be necessary to increase or decrease temperatures by 10°C. It may also be necessary to increase or decrease cooking times.**

## Shelf Positioning

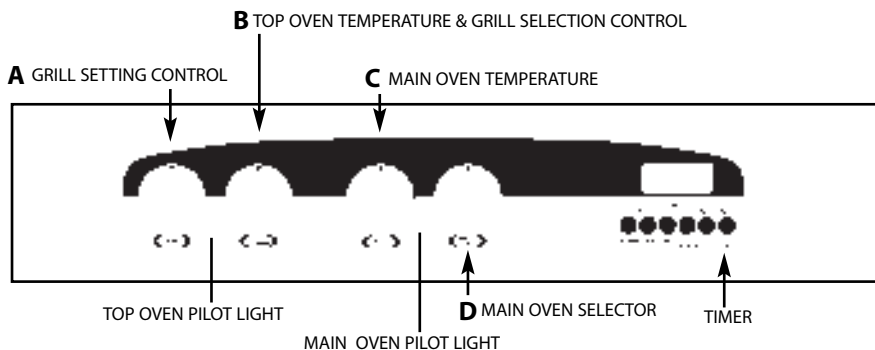


There should always be at least 25mm (1 inch) between the top of the food and the grill element.

**WARNING: Items stored in the top oven will get hot when the main oven is in use.**

**DO NOT allow young children near to the appliance when the top oven is in use as the surfaces get extremely hot.**

# Operation when using the Top Oven as a Convection Oven



**Step 1** Ensure that the Timer is set to Manual.

**Step 2** Place the shelf in the correct position (see Oven Temperature Charts).

**Step 3** Select the required cooking temperature (100–220°C) using control (B) (see Top Oven Temperature Charts).  
The pilot light will immediately come on, and remain on until the oven reaches the required temperature. The light will then automatically go off and on during cooking as the oven thermostat maintains the correct temperature.

**Step 4** Place the food on the shelf directly below the element ensuring the oven door is closed.

**NOTE: At the end of your cooking, always return control (B) to the OFF (●) position.**

## Plate Warming

Place the plates/dishes on shelf position 1 from the base of the top oven, and turn top oven temperature and grill selection control (B) to 100°C for 10-15 minutes.

**Never use the grill setting control (A) when warming plates.**

## Top Oven Utensils

Do Not use: Meat Pans and Baking Trays larger than – 225mm x 300mm (9"x12")

**DO NOT use the main oven meat pan as a meat pan in the top oven, as the air circulation will be seriously restricted.**

---

# Main Oven (Pre-Heat)

---

## Fan Oven Mode

Fan Ovens provide even distribution of heat, allowing food to be cooked anywhere in the oven at the same temperature, ideal for batch baking.

Pre-heating is not necessary in the fan oven mode for most foods because the oven element is situated around the fan blade which in turn circulates the hot air evenly around the oven quickly.

## Side Heat Mode

This is an oven mode long favoured for traditional British cooking.

The heating elements at the side create different temperature zones with the hottest at the top and the coolest at the bottom. This allows you to cook at different temperatures on different shelves.

The unique design of the Creda Smartcook™ oven permits an initial boost that reduces the usual pre-heat time of approximately 15-20 minutes in a non-fan oven to approximately 8-9 minutes (based on 180°C). During the initial boost both the side and the rear elements are on as well as the fan. When the oven reaches temperature in this mode, the fan will remain on for a further 4 minutes after opening the door and will then switch off automatically.

# Using the Main Oven for Fan Cooking

Since a circulaire fan oven heats up more quickly and generally cooks food at a lower temperature than a conventional oven, pre-heating is often unnecessary. For guides on “pre-heating”, “cooking temperatures” and “cooking times” see “Oven Temperature Charts” later in book.

**Note: Charts are a guide only, to suit personal taste and requirements, it may be necessary to increase or decrease temperatures by 10°C. It may also be necessary to increase or decrease cooking times.**

## Main oven shelf positioning for Fan Oven

Most foods will cook satisfactorily on any shelf position, due to even distribution of heat in the main oven, but the shelves must be evenly spaced.

The top oven rod shelf can be used in the main oven when cooking large quantities of food. (N.B. Maximum 3 shelves in the main oven).

**Food or utensils should never be placed directly on the floor of the oven for cooking.**

**DO NOT allow young children near to the appliance when the main oven is in use as the surfaces get extremely hot.**

## Easy Glide™ Shelf

The Easy Glide™ Shelf, in conjunction with the grill pan supplied can be used for cooking in the oven(s), ie. meat, poultry etc. also for roasting vegetables. Place the Easy Glide™ Shelf in the oven on the same runner position as stated in the meat cooking chart.

### Important:

**Always** remove the grill pan handle from the grill pan, when the pan is being used for oven cooking.

**Always** use oven gloves when basting, turning or removing food from the oven, as the Easy Glide™ Shelf and the pan will be hot.

**Never** remove the Easy Glide™ Shelf from the oven with the pan and food still in position.

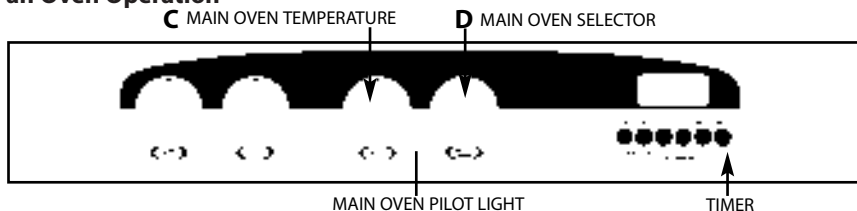
## Main Oven Utensils

Do Not Use: Meat Pans larger than – 375mm x 300mm (15”x12”)  
Baking Trays larger than – 325mm x 250mm (13”x10”)

## Temperature and Time

When all three shelves are in use to cook large quantities of food, it may be necessary to increase the cooking times given in the temperature charts by a few minutes, to allow for the loss of heat due to extra time taken to load the oven, and the larger mass of food. Baking trays should have an even gap around the oven.

## Main Fan Oven Operation



- Step 1 Check that the timer is in manual.
- Step 2 Place the shelf/shelves in the correct position, See Oven Temperature Charts (Main Fan Oven).
- Step 3 Place the food centrally on the shelf ensuring the oven door is fully closed.
- Step 4 Select Fan Oven cooking, by turning control (D) clockwise to 'FAN OVEN'.
- Step 5 Select the required cooking temperature (80 to 230°C) by turning control (C) clockwise. The pilot light will immediately come on, and remain on until the oven reaches the required temperature. The light will then automatically go off and on during cooking as the oven thermostat maintains the correct temperature.

**Note: When you have finished using your cooker, always return the controls to their OFF (●) position. At the end of the cooking period there may be a momentary puff of steam when the door is opened. This will disperse in a few seconds and is a perfectly normal characteristic of an oven with a good door seal.**

## Using the Main Oven for Convection Cooking (Side Heat)

With convection cooking the oven needs to be pre-heated before use. For guides on “pre-heating”, “cooking temperatures”, “cooking times” and shelf positions, see “Oven Temperature Charts” (convection cooking) later in book.

**Note: Charts are a guide only, to suit personal taste and requirements, it may be necessary to increase or decrease temperatures by 10°C. It may also be necessary to increase or decrease cooking times.**

### Main oven shelf positioning for Convection Cooking

Shelves must be positioned as recommended in the cooking charts (convection oven)

(N.B. A maximum of 2 shelves to be used in the main oven).

**Food or utensils should never be placed directly on the floor of the oven for cooking.**

**DO NOT allow young children near to the appliance when the main oven is in use as the surfaces get extremely hot.**

### Easy Glide™ Shelf

The Easy Glide™ Shelf, in conjunction with the grill pan supplied can be used for cooking in the oven(s), ie. meat, poultry etc. also for roasting vegetables. Place the Easy Glide™ Shelf in the oven on the same runner position as stated in the meat cooking chart.

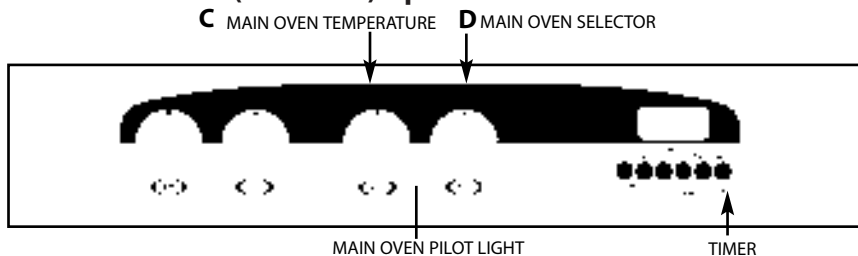
#### Important:

**Always** remove the grill pan handle from the grill pan, when the pan is being used for oven cooking.

**Always** use oven gloves when basting, turning or removing food from the oven, as the Easy Glide™ Shelf and the pan will be hot.

**Never** remove the Easy Glide™ Shelf from the oven with the pan and food still in position.

### Main Convection Oven (Side Heat) Operation



- Step 1 Check that the timer is in manual.
- Step 2 Place the shelf/shelves in the correct position, See Oven Temperature Charts (Convection Oven).
- Step 3 Place the food centrally on the shelf ensuring the oven door is fully closed.
- Step 4 Select Convection cooking (side heat), by turning control (D) anti-clockwise to ‘SIDE HEAT’.
- Step 5 Select the required cooking temperature (80 to 230°C) by turning control (C) clockwise. The pilot light will immediately come on, and remain on until the oven reaches the required temperature. The light will then automatically go off and on during cooking as the oven thermostat maintains the correct temperature.

#### Important:

When Side Heat cooking has been started and the controls are then switched OFF and ON again for any reason the boost sequence will then re-start.

**Note: When you have finished using your cooker, always return the controls to their OFF (●) position. At the end of the cooking period there may be a momentary puff of steam when the door is opened. This will disperse in a few seconds and is a perfectly normal characteristic of an oven with a good door seal.**

---

# Using the Main Oven for Other Functions

---

90

## “SLOW” Setting (FAN OVEN only)

This is used for slow cooking, keeping food warm and warming plates for short periods. Extra care should be taken when warming bone china, as it may be damaged in a hot oven.

**DO NOT place food or plates directly on the oven floor as this could damage both the oven lining and the plates which are being warmed.**

### Advantages of “SLOW” cooking are:

The oven stays cleaner because there is less splashing.  
Timing of food is not as critical, so there is less fear of overcooking.  
Inexpensive joints of meat are tenderised.  
Fully loading the oven can be economical.  
Cooking times can be extended in some cases by up to 2 hours.  
The kitchen stays cooler.

### Operation:

1. Place the prepared food in the main oven and ensure the door is fully closed.
2. Turn the Main Oven selector (D) clockwise to the FAN OVEN position.
3. Select **90** (Slow Cooking Temperature) by turning Main Oven Temperature

Control (C) clockwise ensuring the oven door is fully closed.

### Storage and re-heating of food:

1. If food is to be frozen or not used immediately, place it in a clean container and cool as soon as possible.
2. Always thaw frozen food completely in the refrigerator before re-heating.
3. Always reheat food thoroughly and ensure it is piping hot before serving.
4. Only re-heat food **once**.

### Points to consider when preparing food for “SLOW” cooking:

1. Make sure that the dishes to be used will fit into the oven ensuring enough room for air to circulate.
2. All dishes cooked on the slow setting will require a minimum of 6 hours, however, if they are cooked for 1-2 hours longer then deterioration in their appearance may be noticed.
3. Never cook joints of meat over 2.7kg (6 lb) or poultry over 2.0kg (4lb 8oz). We do not recommend that joints of meat or poultry are stuffed before cooking on the slow setting.
4. To seal in the meat juices, always cook meat or poultry at 170°C for 30 minutes before wrapping in foil and placing on a rack over a tin (to allow good air circulation) before turning the control to the slow setting and cooking immediately.
5. Always ensure that joints of pork and poultry are thoroughly cooked by checking with a meat thermometer before serving.
6. Always thaw frozen foods completely before cooking. We do not recommend placing frozen food in the oven to cook.
7. Always bring soups, liquids and casseroles to the boil before placing in the oven.
8. Ensure that casserole dishes have a good seal (not airtight) and cover to the top with foil to prevent loss of moisture.
9. Ensure that fruit and vegetables are cut into even sized small pieces to cook properly.
10. Always adjust seasoning before serving.
11. If using dried red kidney beans it is important that the beans are soaked and then boiled for a minimum of 10 minutes before using in any dish to destroy any toxins.
12. When cooking fish or egg dishes it may be necessary to check during cooking to avoid overcooking.



---

## Temperature Conversion Chart

---

<b>Gas Mark</b>	<b>°F</b>	<b>Main Conventional Oven</b>	<b>Top Convection Oven</b>	<b>Main Fan Oven</b>
1/2	250	120	110	100
1	275	140	130	120
2	300	150	140	130
3	325	160	150	140
4	350	180	170	160
5	375	190	180	170
6	400	200	190	180
7	425	220	210	200
8	450	–	220	210
9	475	–	–	220

# Top Oven Temperature Charts - Meat

Top Oven Cooking				
Meat	Pre-heat	Temperature °C	Time (approx.)	Position in Oven
Beef/ Lamb (slow roasting)	Yes	170/180	35 mins per 450g (1lb) + 35 mins over.	Runner 1 from bottom of oven.
Beef/ Lamb (foil covered)	Yes	190/200	35-40 mins per 450g (1lb)	
Pork (slow roasting)	Yes	170/180	40 mins per 450g (1lb) + 40 mins over	
Pork (foil covered)	Yes	190/200	40 mins per 450g (1lb)	
Veal (slow roasting)	Yes	170/180	40-45 mins per 450g (1lb) + 40 mins over	
Veal (foil covered)	Yes	190/200	40-45 mins per 450g (1lb)	
Poultry/Game (slow roasting)	Yes	170/180	25-30 mins per 450g (1lb) + 25 mins over	
Poultry/Game (foil covered)	Yes	190/200	25-30 mins per 450g (1lb)	
Casserole Cooking	Yes	150	2-2½ hrs	

## COOKING MEAT/POULTRY IN THE TOP OVEN

Small joints of meat up to 1.5Kg (3 lbs) and poultry up to 3.6Kg (8lbs) can be roasted in a small meat pan in the top oven.

## IF USING ALUMINIUM FOIL

1. Never allow foil to touch sides of oven.
2. Never cover interior with foil.
3. Never cover shelves with foil.

The most accurate method of testing the readiness of joints of meat or whole poultry is to insert a meat thermometer into the thickest part of a joint of meat, or the thickest part of poultry thighs, during the cooking period. The meat thermometer will indicate when the required internal temperature has been reached.

Beef			Pork	Lamb	Poultry
Rare 60°C	Medium 70°C	Well Done 70°C	90°C	80°C	90°C

## Top Oven Temperature Charts - Baking

Baking	Convection Cooking Top Oven			
Food	Pre-heat	Temperature °C	Time in mins.	Position In Oven
Scones	Yes	200	9-12	Runner 1 from bottom of oven
Small Cakes	Yes	180	15-20	Runner 1 from bottom of oven
Victoria Sandwich	Yes	170	20	Runner 1 from bottom of oven
Sponge Sandwich	Yes	180/190	15	Runner 1 from bottom of oven
Swiss Roll	Yes	190/200	9-12	Runner 1 from bottom of oven
Semi-rich Fruit cakes	Yes	150/170	60-90	Runner 1 from bottom of oven
Rich Fruit Cakes	Yes	150	120-135	Runner 1 from bottom of oven
Shortcrust Pastry	Yes	190/200	40-45	Runner 1 from bottom of oven
Puff Pastry	Yes	200/220	Depending on use	Runner 1 from bottom of oven
Yorkshire Pudding	Yes	190/200	40-45	Runner 1 from bottom of oven
Individual Yorkshire Puddings	Yes	200/210	40-45	Runner 1 from bottom of oven
Milk Pudding	Yes	140	105-135	Runner 1 from bottom of oven
Baked Custard	Yes	150	45-50	Runner 1 from bottom of oven
Bread	Yes	200/210	25-30	Runner 1 from bottom of oven
Meringues	Yes	100	150-180	Runner 2 from bottom of oven

**Note:** If soft tub margarine is used for cake making, we would recommend using the all in one method and to reduce the temperature by 10°C. Temperatures recommended in this chart refer to cakes made with block margarines or butter only.

## Main Oven Temperature Chart - Meat

Food	Side Heat Oven Cooking (Main Oven)				Food	Fan Oven Cooking (Main Oven)		
	Pre-heat	Temperature °C	Time (approx.)	Shelf Position (from base of oven)		Meat	Pre-heat	Temperature °C
Beef	Yes	190/200	approx 25-30 mins per 450g (1 lb) + 25 mins extra	2	Beef	No	160/180	20-25 mins per 450g (1lb) + 20 mins extra
Lamb	Yes	190/200	approx 25-30 mins per 450g (1 lb) + 25 mins extra	2	Lamb	No	160/180	20-30 mins per 450g (1lb) + 25 mins extra
Pork	Yes	190/200	approx 30-35 mins per 450g (1 lb) + 30 mins extra	2	Pork	No	160/180	20-30 mins per 450g (1lb) + 25 mins extra
Veal	Yes	190/200	approx 25-35 mins per 450g (1 lb) + 30 mins extra	2	Veal	No	160/170	25-30 mins per 450g (1lb) + 25 mins extra
Poultry / Game	Yes	190/200	approx 25-30 mins per 450g (1 lb) + 20 mins extra	2	Chicken/Turkey up to 4kg (8lb)	No	160/180	15-20 mins per 450g (1lb) + 20 mins extra
Turkey	Yes	190	Up to 5.5kg (12 lb) allow 22 mins per 450g (1 lb)	2	Turkey up to 5.5kg (12lb)	No	150/160	12-14 mins per 450g (1lb) + 12 mins extra
		180	Over 5.5kg (12 lb) allow 16 mins per 450g (1 lb)			No	150	10 mins per 450g (1lb) eg, 10kg (22lb) = 264 mins
Casserole / Stews	Yes	140/160	Depending on quantity.	2	Casserole / Stews	No	140	1 1/2 - 2 hours

The above times and temperatures are for open roasting. Cooking times may need to be increased when covering food with foil.

**IF USING ALUMINIUM FOIL 1. Never allow foil to touch sides of oven. 2. Never cover interior with foil. 3. Never cover shelves with foil.**

The most accurate method of testing the readiness of joints of meat or whole poultry is to insert a meat thermometer into the thickest part of a joint of meat, or the thickest part of poultry thighs, during the cooking period. The meat thermometer will indicate when the required internal temperature has been reached.

Beef		Pork	Lamb	Poultry
Rare 60°C	Medium 70°C	Well Done 70°C	80°C	90°C

# Main Oven Temperature Chart - Baking

Baking	SIDE HEAT Oven Convection Cooking (Main Oven)					Fan Oven Cooking		
	Pre-heat	Temperature °C	Time	Shelf Position (from base of oven)	Pre-heat	Temperature °C	Time in mins.	
Scones	Yes	220/230	10-16 mins	2 and 5	Yes	210/220	8-10	
Small Cakes	Yes	190/200	15-25 mins	2 and 5		170/180	15-20	
Victoria Sandwich	Yes	180/190	20-30 mins (2 x 8" tins)	2 and 5		160/170	20-25	
Sponge Sandwich (Fatless)	Yes	190/200	15-20 mins (2 x 7" tins)	2 and 5	Yes	170/190	15-20	
Swiss Roll	Yes	180/200	12-15 mins	5	Yes	180/200	12-15	
Semi-rich Fruit Cake	Yes	170/180	1 1/4-1 1/2 hours	3		140/150	75-90	
Rich Fruit Cakes	Yes	140/150	Time depending on size and richness of mixture.	3		130/140	Depending on size.	
Shortcrust Pastry	Yes	200/210	50 mins - 1 hour	2 and 5		190/200	45-50	
Puff Pastry	Yes	220	Time depending on recipe.	5		190/200	Depending on use.	
Yorkshire Pudding	Yes	210/220	40-45 mins	5	Yes	180/190	40-45	
Individual Yorkshire Pudding	Yes	210/220	20-25 mins	5	Yes	190/200	20-25	
Milk Pudding	Yes	150/160	2 - 2 1/2 hours	3		130/140	105-135	
Baked Custard	Yes	150/160	40-50 mins	3		140/150	40-50	
Bread	Yes	230	45-60 mins Reducing to 220°C after 10 mins	2 and 5	Yes	200/210	45-50	
Meringues	Yes	100/110	Large 3 1/2 - 4 1/2 hours Small 2 1/2 - 3 hours	2 and 5		80-90	180-240	

**Note:** If soft tub margarine is used for cake making, we would recommend using the all in one method and to reduce the temperature by 10°C. Temperatures recommended in this chart refer to cakes made with block margarines or butter only.

**Note:** When using two shelf positions at the same time on SIDE HEAT (eg. to bake two apple pies or a full oven of bread) the items should be interchanged half way through the cooking period. When baking two trays of scones or small cakes, the lower tray may require a few minutes longer and to be moved up to the higher position.

---

# Cooking Results Not Satisfactory

---

## GRILL

- Uneven cooking front to back** Ensure that the grill pan is positioned centrally below the grill element.
- Fat splattering** Ensure that the grill pan is not lined with foil.  
Ensure that the grill setting control (A) is not set too high.  
If Solarplus grill – use anti-splash tray supplied under the food support.

## BAKING GENERAL

- Uneven rising of cakes** Ensure that the oven shelves are level.
- Sinking of cakes** The following may cause cakes to sink:
1. Pre-heating of fan ovens – not always necessary.
  2. Cooking at too high a temperature – reduce standard temperatures by 25°C for fan ovens.
  3. Using normal creaming method with a soft margarine.  
If using soft margarine, use an all in one method instead of the traditional creaming of the margarine and sugar.  
Remember when using a food mixer or processor not to over-cream soft margarine.
- Over/undercooking** Refer to the cooking times and temperatures given in the Oven Temperature Charts provided, however, it may be necessary to increase or decrease temperatures by 10°C to suit personal taste.
- Do not use utensils greater than 56mm (2¼") in height for roasting.

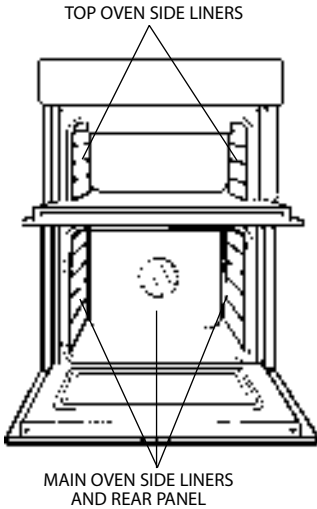
## TOP OVEN BAKING

- Uneven cooking front to back** Ensure that the cooking utensil is at least 100mm (4") from the front of the shelf.
- Uneven rising** Ensure that the shelf is level (as above) and that the food is positioned correctly in the oven.
- Overcooking** Remember to reduce cooking temperatures by 10°C from standard recipes when using the top oven.
- Food is taking too long to cook** Ensure that the cooking utensil used in the top oven is not larger than 300mm x 225mm (12"x 9"), e.g. **Do Not** use the main oven meat pan.
- Only cook one item at a time to avoid overloading the oven.

# Care and Cleaning

**Warning: Before cleaning, please ensure that the electricity supply to the appliance is switched off and the appliance is fully cold.**

## 1. "CREDACLEAN" OVEN LINERS (TOP OVEN) (E530E)



### (a) How "Credaclean" works.

The surfaces of the "Credaclean" oven liners are treated with a special vitreous enamel which absorbs cooking soils. At temperatures of 220°C (425°F) or above, the special surface enables these soils to be slowly destroyed. The higher the temperature the more effective it is.

### (b) Cleaning.

In most cases normal cooking operations at 220°C (425°F) will permit this cleaning operation to proceed during cooking. However if higher cooking temperatures are not used regularly, it may be necessary, in order to prevent heavy soiling, to run the ovens without shelves or meat pan, at a maximum setting for a couple of hours. It should not normally be necessary to clean the "Credaclean" panels with water. If the user feels it is desirable to do so, wipe them over with a clean, soapy cloth, followed by a wipe with a clean damp cloth.

## 2. VITREOUS ENAMEL OVEN LINERS (TOP OVEN) (R530E)

### Cleaning.

These can be cleaned by wiping them over with a clean soapy cloth, followed by a wipe with a clean damp cloth. For more stubborn stains on the side liners use a well soaped, fine steel wool soap pad.

## 3. OVEN LINERS (MAIN OVEN)

### Cleaning. Enamel coating:

These can be cleaned by wiping them over with a clean, soapy cloth, followed by a wipe with a clean damp cloth or in a dishwasher (see below removal / refitting instructions). For more stubborn stains on the side liners, use a well soaped fine steel wool soap pad.

### Removal / Refitting.

(a) **To remove liners:** Grip at the bottom and lift upwards and remove from the oven for cleaning.

(b) **To refit liners:** Place the liner over the four shoulder screws and slide downwards, ensuring all four corners are engaged correctly and the hand grip is positioned towards the bottom of the oven.

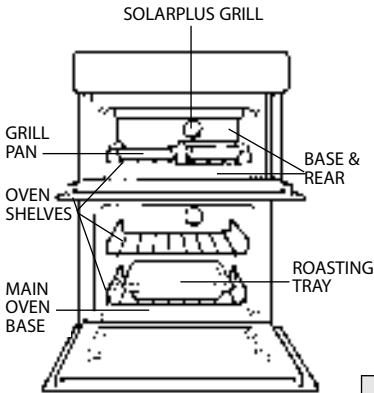
**DO NOT use biological washing powder, harsh abrasives or chemical oven cleaners of any kind as this could damage the "Credaclean" and Vitreous Enamel oven liners.**

---

# Care and Cleaning

---

## 4. CLEANING GRILL, TOP OVEN AND MAIN OVEN



### (a) Base & Rear of Top Oven and Base of Main Oven.

Wipe out the oven with a damp soapy cloth. For more stubborn stains on the base of the oven use a well soaped fine steel wool soap pad.

### (b) Grill Pan, Meat Pans & Oven Shelves etc.

To prevent stains from being burnt on to the grill pan, food support and rod shelf, always wash immediately after use in hot soapy water.

Use a well soaped fine steel wool soap pad to remove stubborn stains from the rod shelves, grill pan, meat pan and the base of the oven.

NOTE: Take care when cleaning the Easy Glide™ Shelf not to trap fingers between mating parts.

**DO NOT use aerosol cleaners on this oven as they could adversely affect the fan motor unit, and cannot be wiped off the fan blade.**

### (c) Solarplus Grill

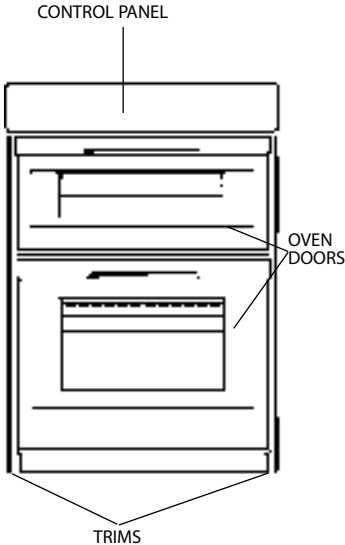
To clean the Solarplus grill, use a clean, damp, soapy cloth and wipe over. If stubborn stains remain, gently clean with a well soaped nylon scouring pad and wipe over with a damp cloth.

**DO NOT use metal cleaning utensils, wire wool or proprietary oven cleaners on the grill element mesh.**



# Care and Cleaning

## 5. OVEN DOORS



### (a) Control Panel

Regularly wipe with a clean, damp cloth and polish with a clean, dry cloth.

### (b) Trims

It is advisable to clean the trims regularly to prevent any build up of soiling which may detract from the appearance of the cooker. The recommended method of cleaning is to wipe over the trims with a clean, soft cloth wrung out in hot water, or mild non abrasive cleaner.

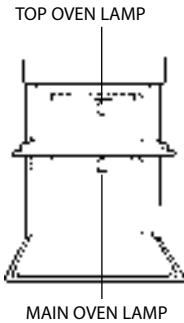
(If in doubt try the cleaner on a small area of trim which is not noticeable in normal use), then after wiping with a cloth wrung out in clear water, dry with a clean, soft cloth.

### (c) Inner Door Panels & Glass

Open the door fully. The glass panel may now be washed. Stubborn stains can be removed by using a well soaped, fine steel wool soap pad.

**DO NOT use scouring pads, or abrasive powder, which will scratch the glass.**

## 6. REPLACEMENT OF THE OVEN LAMP



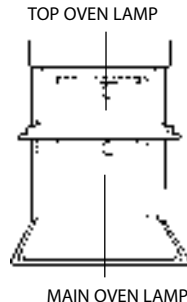
**Warning: Before removing lamp lens, please ensure that the electricity supply to the appliance is switched off and the appliance is fully cold.**

Open the oven door and remove the oven shelves.

Using a thick cloth, grip the lamp lens, unscrew anti-clockwise and remove the lens.

Carefully unscrew the bulb anti-clockwise. Fit replacement bulb (15W 300°C SES). Fit replacement bulb and refit lens.

## 7. HOW TO CLEAN THE LAMP LENS



**Warning: Before cleaning lamp lens, please ensure that the electricity supply to the appliance is switched off and the appliance is fully cold.**

Open the oven door and remove the oven shelves.

Using a thick cloth, grip the lamp lens, unscrew anti-clockwise and remove.

Clean with a non-abrasive cleansing cream and refit lamp lens.

**DO NOT use scouring pads, or abrasive powder, which will scratch the glass lens**

---

# Care and Cleaning

---

Take particular care not to damage the inner surface of the door inner glass that is coated with a heat reflective layer. Do not use scouring pads, or abrasive powder, which will scratch the glass. Ensure that the glass panel is not subjected to any sharp mechanical blows.

Stubborn stains can be removed by using a fine steel wool pad. For slight soiling the inner glass panel may be cleaned, while still warm, without removing it from the door. After cleaning, rinse and dry with a soft cloth.

## CLEANING THE DOORS

### SIDE OPENING DOORS

Cleaning the door glass is the same as the drop down doors, except take care to support the weight of the inner glass when removing and refitting.

### DROP DOWN DOORS

Remove the door inner glass as follows.

1. Open the door fully and unscrew the two screws securing the glass panel so that the securing brackets can be turned. There is no need to remove the screws completely.
2. Turn the brackets so that the glass can be removed and cleaned at the sink (Fig. 1.)

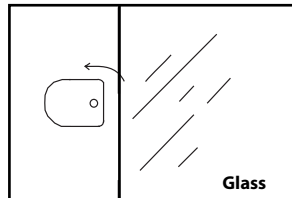


Fig. 1.

3. The inside of the outer door glass can now be cleaned while still fitted to the cooker.

## NEVER OPERATE THE COOKER WITHOUT THE INNER DOOR GLASS IN POSITION.

Refit the door inner glass as follows.

1. **NOTE:** The inner door glass has a special reflective coating on one side. Replace the door inner glass so that the statement: **"IMPORTANT THIS FACE TOWARDS THE OVEN"** can be read from the inner side of the door.
2. Turn the two securing brackets back to their original position to retain the glass and tighten the screws. (Fig. 2.)

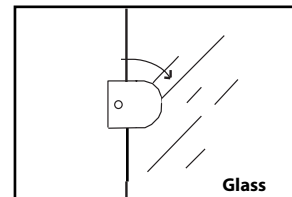


Fig. 2.

---

# Installation

---

## Electrical Requirements

For your own safety, we recommend that your cooker is installed by a competent person such as one who is registered with NICEIC (National Inspection Council for Electrical Installation Contracting). The cooker should be installed in accordance with the latest edition of the IEE Regulations.

**Warning: This appliance must be earthed.**

## Electrical Connections

The installer must check that the voltage shown at the rating plate corresponds with the house electricity supply.

The cooker must be supplied via a suitable double pole isolating switch, having a contact separation of at least 3mm in all poles placed in a readily accessible position adjacent to the cooker.

If the cooker is to be wired into a connector unit, this may be positioned behind the cooker providing the following requirements are met:

- i) The connector unit must not project from the wall more than 25mm.
- ii) The top of the connector must not be more than 130mm above floor level.

Remove the terminal cover at the rear base of the cooker. Pass the cable through the cable clamp and connect to the appropriate terminals provided.

Allow sufficient cable for any future servicing.

Tighten the screws on the cable clamp and replace the cover.

Make main connections in the connector unit or cooker control unit.

This appliance conforms to B.S. EN 55014 regarding suppression of Radio and Television reception interference.

A double Pole control switch having a minimum rating of 32 amps should be used to feed the cooker using a suitably rated cable.

Where a hob is fitted adjacent to or over the cooker, a 45 amp Double Pole control switch should be used to feed both units via separate suitably rated cables.

We recommend a minimum of 4mm<sup>2</sup> PVC insulated twin and earth cable conforming to B.S. 6004 for connection of each appliance.

Where a hob is fitted above the cooker the cable connecting the hob to the cooker control unit must be of 2.5mm<sup>2</sup> 85°C heat resistant cable to BS6141 table 15

**In all cases adhere to routing details (see fig. 5).**

This appliance must not be installed over any other appliance that generates heat such as a plinth heater

**Note: Due to many different types of installation, a mains cable is not supplied with this product. The installer will fit the correct type and length of cable.**

---

# Installation

---

## Important

It is essential that the lower cupboard is constructed in the manner illustrated i.e. having side, back, and roof panels so joined as to provide no apertures which could permit access to the oven unit when installed.

### 1. General

The appliance is designed for mounting at a safe level into an oven housing which must be secured to the backing wall.

### 2. Ventilation

- a. The oven housing unit cabinet dimensions must comply with fig. 4.
- b. An air gap of 50mm minimum must be provided at the rear of any top or bottom cupboards or shelves (see fig. 1).
- c. It is necessary that the cabinets are provided with unobstructed ventilation, i.e. from adjacent cabinetry. This can be done by either raising the base of the cabinets using the adjusting feet (or spacers) or alternatively by providing a slot in the cabinet plinth to the dimensions in fig. 1.
- d. The air gap at rear allows the warmed air to pass out of the inner cabinet space. Where it is intended to fit cupboards above the oven unit to ceiling height, it is essential that the warmed air is exhausted through the front of the cabinet (see fig. 1).
- e. If an oven unit is installed adjacent to a tall cabinet, steam escaping from the oven when the door is opened could condense on and maybe stain the adjacent surface. To prevent permanent staining, the adjacent surface should be made of a material that is heat resisting and easy to clean. Adjacent tall cabinets should not be deeper than the oven housing cabinet.

### 3. Final Installation

- a. Using a spirit level, check that the housing cabinet is level from side to side and from front to back in its installed position.
- b. Correct any unevenness by placing spacers under the bottom of the cabinet. Make sure that the cabinet rests firmly on the floor without rocking.
- c. Before the oven is fitted, the cabinet must be firmly secured to the backing wall for stability.
- d. The oven unit should now be lifted (this is a two person lift) into the cabinet and pushed fully home.
- e. Finally, the oven is secured to the cabinet by means of the four Pozi Wash Head screws - two through each side trim.
- f. Remove all packaging material from the grill and oven interior.

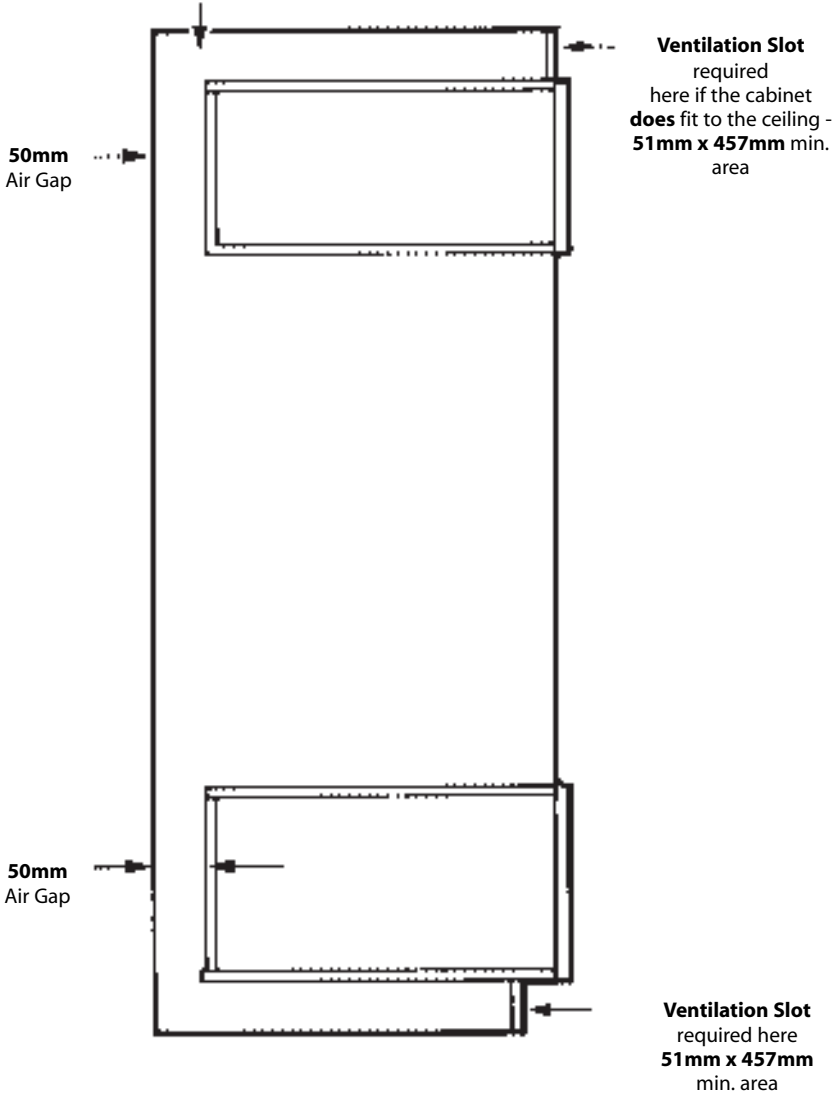
### List of loose items:

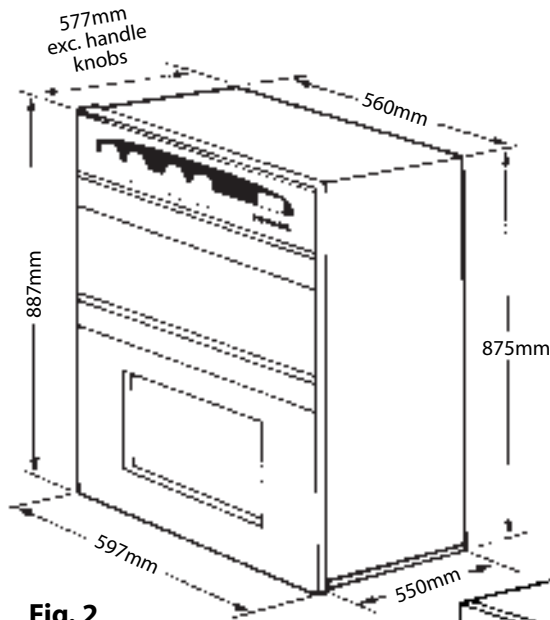
4 x Pozi Wash Head No. 6 x 15mm screws.

# Tall Cabinet Ventilation

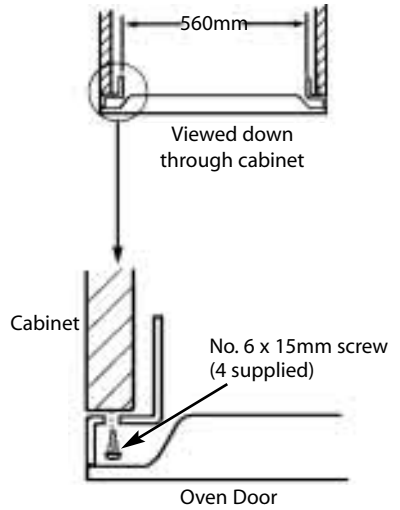
Fig. 1

Ventilation Slot required here if cabinet **does not** fit to ceiling - **51mm x 457mm** min. area

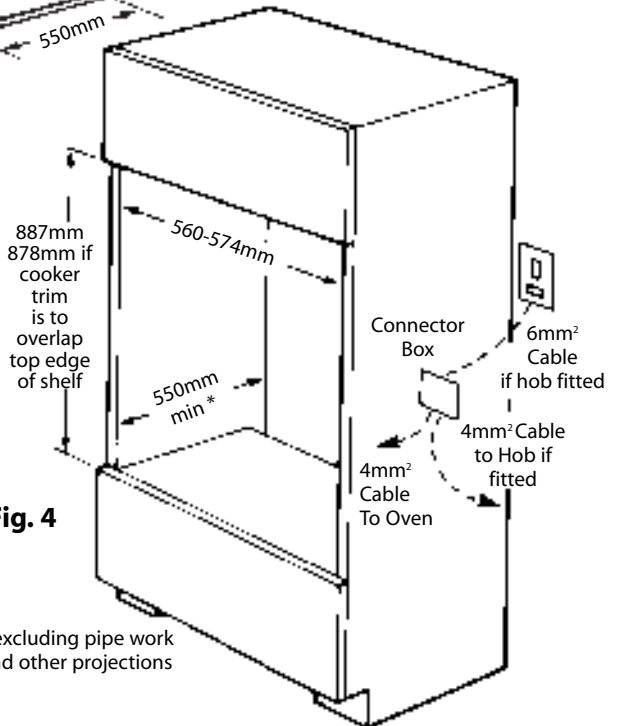




**Fig. 2**



**Fig. 3**



**Fig. 4**

\* excluding pipe work  
and other projections

# Something Wrong?

**Before calling a Service Engineer, please check through the following lists.  
THERE MAY BE NOTHING WRONG.**

<b>Problem</b>	<b>Check</b>
<b>Slight odour or small amount of smoke when grill / oven used first time</b>	This is normal and should cease after a short period.
<b>Nothing works.</b>	If you find that the timer display is blank, then it is likely that there is no electricity supply to your oven. Check: (i) That the main cooker wall is switched on (ii) Other appliances, to see if you have had a power cut (iii) The main circuit breaker for the property
<b>Display shows 0.00 AUTO.</b>	The power supply to your oven has possibly been interrupted, but has now come back on again. Reset the timer to the correct time of day and "Manual" operation using instructions given in the timer section of the book.
<b>Main Oven does not work, but the Grill and Top Oven work.</b>	Your timer may be set for an Auto Cooking programme: Check the timer to see whether "Auto" is lit or flashing. If it is then please follow the instructions given in the Timer section of this book to return the timer to Manual operation.
<b>Top Oven and Grill do not work, but the Main Oven works.</b>	Operating the cooker under the following conditions may cause a safety device to operate: (a) Grilling with the door closed - Always grill with the door fully open (b) Grilling for an excessively long period at maximum setting - see Grilling guide. Switch off appliance and allow to cool for approx 30 mins. Switch the cooker back on and check that the Grill / Top oven is now operating.
<b>Grill does not work.</b>	Check that you have selected:- "Grill" function on the "Top Oven / Grill Select" knob (B) <b>and</b> a Grill setting on the "Grill" knob (A) - see grilling page.
<b>Grill keeps turning on and off.</b>	When the Grill control is operating at less than its maximum setting, the Grill will cycle on and off, this is normal and <b>not</b> a fault.
<b>Can not set an "Auto Cook" programme</b>	Remember: "Cook Period" is the actual length of time for which, the timer will switch the main oven on as part of an "Auto Cooking" programme.
<b>Draught from beneath control panel.</b>	A gentle flow of air will be blown from beneath the control panel when the appliance is used. If the appliance is still warm, this cooling fan may run on, or restart itself after all of the controls have been turned off. The fan will stop once the appliance has been cooled. This is normal and <b>not</b> a fault.
<b>Timer buzzer/bleeper operates continually</b>	Buzzer/Beeper should stop automatically after 2 minutes. If not, press minute minder button to silence.
<b>Grilling is uneven</b>	Ensure that Grill pan has been positioned as stated in the Grilling section of this book.
<b>Oven does not cook evenly</b>	Check: (a) Temperature and shelf positions are as recommended in the Oven Temperature Charts. (b) Oven utensils being used allow sufficient air flow around them.
<b>Oven temperatures too high or low</b>	Check temperature and shelf positions are as recommended in the Oven Temperature Charts. It may be necessary to increase or decrease the recommended temperature slightly to suit your taste.
<b>Oven lamp does not work</b>	The oven lamp is not covered by the guarantee. The part is easily changed (see the section on oven lamp replacement). A new lamp may be obtained from our Parts department (see Back Cover).
<b>Condensation on the wall at the rear of the cooker.</b>	Steam and / or condensation may appear from the vent at the rear of the appliance when using an oven particularly for foods with a high water content e.g. frozen chips, roast chicken etc. This is normal, and any excess should be wiped off.
<b>Steam / Condensation in the oven after use.</b>	Steam is a by - product of cooking any food with a high water content. To help minimise always: a) Try to avoid leaving food in the oven to cool after being cooked. b) Use a covered container, wherever possible.

**If you have been through the above list and there is still a problem, contact your nearest Service Office (see back cover).**

# **Key Contacts**

## **Service**

Creda has the largest appliance manufacturer's service team in Europe, trained specialists directly employed by us to ensure your complete confidence.

### **Repair Service**

**UK: 08709 066 066**

**Republic of Ireland: 1850 302 200**

You will be asked for the following information:-

Name, address and postcode.

Telephone number

Model / Serial number of the appliance

Clear and concise details of the query or fault

Place and Date of purchase

(Please keep the receipt as evidence will be required when the engineer calls).

### **Extended Warranty**

**To join: UK 08709 088 088**

**Republic of Ireland: 1850 502 200**

### **Genuine Parts & Accessories**

#### **Mail Order Hotline**

**UK: 08709 077 077**

**Republic of Ireland: (01) 842 6836**

For further product information 08701 546474

All Creda Services are offered as an extra benefit and do not affect your statutory rights.

# **Creda**

General Domestic Appliances Limited, Morley Way, Peterborough, PE2 9JB